

# K.D. LOCKER

# ASSEMBLY INSTRUCTIONS

*These Instructions Cover 3 Types of Lockers: VANGUARD, GUARDIAN AND INVINCIBLE II*

## CONTENTS

General Instructions	1
Major Locker Components	2
Hardware and Small Locker Parts	3
Basic Assembly Single Row Lockers	4-5
Installing Coat Rods	4
Guidelines for Rear Leg Spacing	4
Hook and Coat Rod Guidelines	6
Defiant Locker: Assembly of Anti-Pry/Twist Bracket	6
Multi-Tier Lockers	7
Two Person/Duplex/Dual Lockers	7
Basic Assembly of Double Row Locker	8
Individual Closed Bases	9
Zee Base	9
Unit Slope Tops, Slope Top Kits, Continuous Slope Hoods	10
16 Person and Wall Mounted Lockers	11
Invincible II Group End Kits	12
Double Row Invincible II Lockers	12

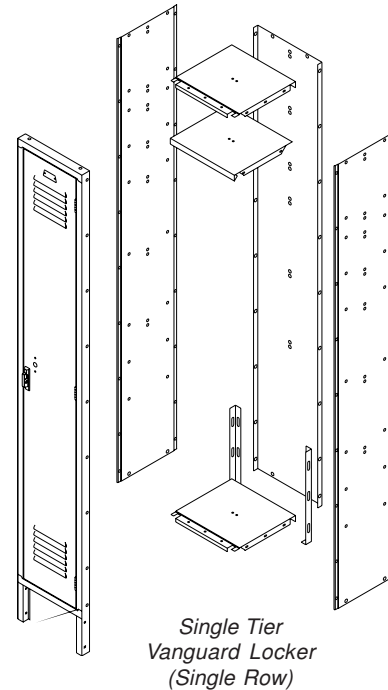

## GENERAL INSTRUCTIONS

1. These instructions are for the person who will actually perform or supervise the assembly of the lockers.
2. Check material received against the packing list. First check the number of packages received and then check the contents of each package.
3. Check material received for damage. If any of it is damaged, secure a "damage notation" from the carrier.
4. Identify each part as it is unpacked and put like parts together as close as possible to the working area in which they are to be assembled.
5. Be careful to use the correct hardware as specified in the assembly instructions.

## CAUTION

It is the responsibility of the persons assembling the lockers to properly install all components and hardware as specified in these instructions and any accompanying drawings for specific installation.

INSTALL ALL UNITS PLUMB  
TIGHTEN ALL HARDWARE SECURELY

# MAJOR LOCKER COMPONENTS For 1,2,3,4,5,6 TIER AND MULTI-TIER DOORS

## Flat Top Locker Body Parts

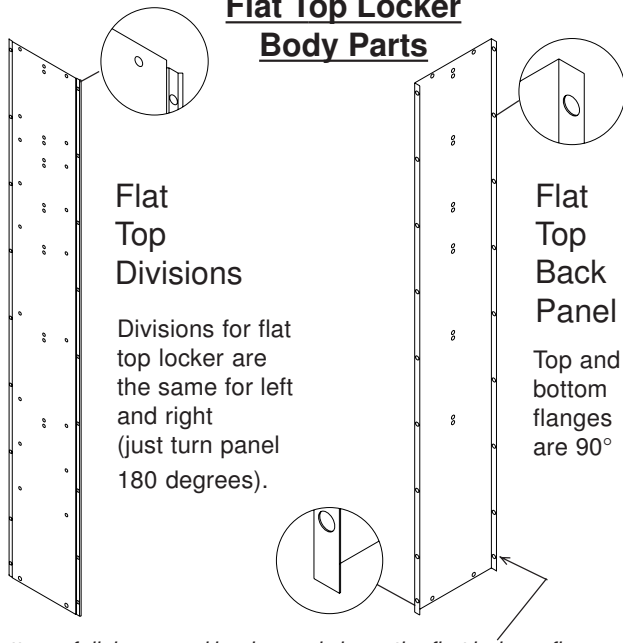

## Slope Top Locker Body Parts

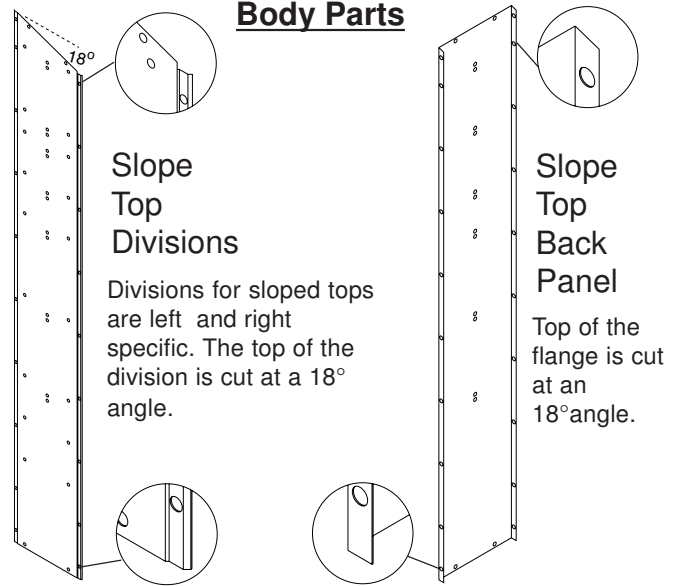

Bottom of divisions and back panels have the first hole on flange 1-3/4" from edge, (top of divisions and back panel have the first hole 1-1/4" from edge).

## Examples of Locker Door and Frame Assemblies

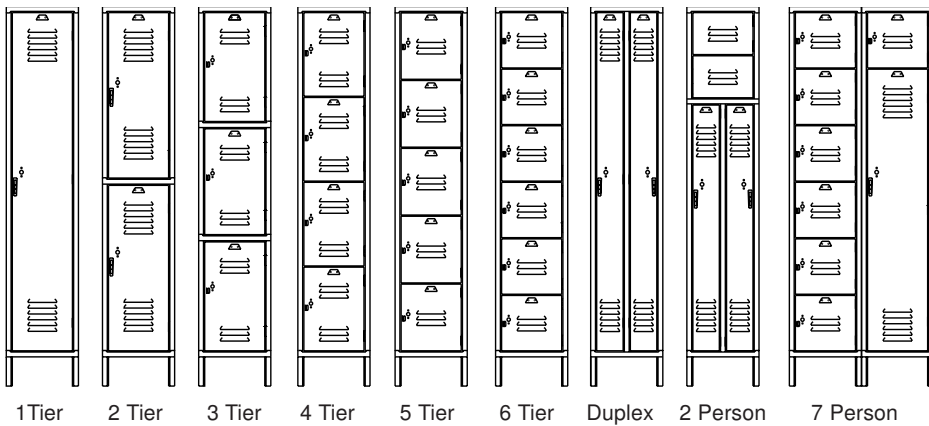

## 2 Person, Dual and Duplex Parts

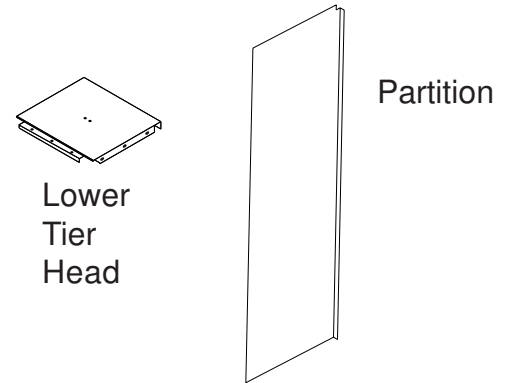

## Divisions for Double Row Lockers

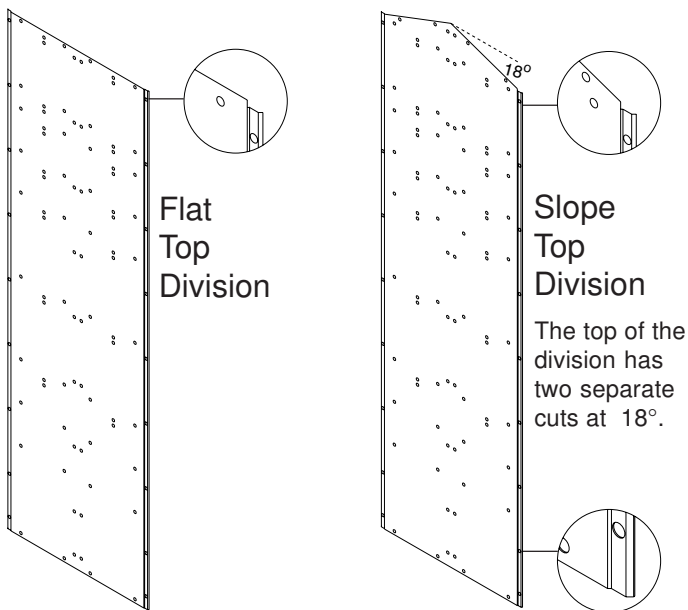

## Locker Tops, Bottom (T.A.B.) and Shelves

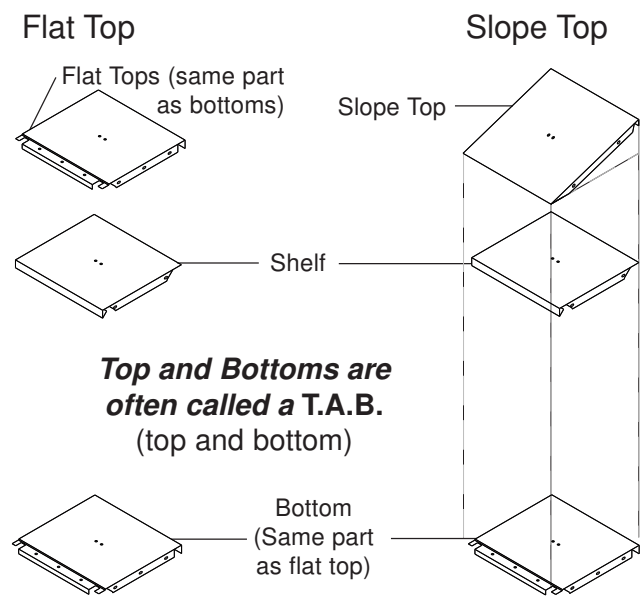

Single row lockers must be floor and wall anchored, double row lockers must be floor anchored and if possible wall or ceiling anchored.

# HARDWARE AND SMALL LOCKER PARTS

Not all parts come with all lockers. Check packing list for what parts are to be used with what models of lockers.



**Number Plate and Rivet**  
To be riveted to top of locker door.

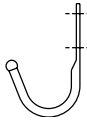

**Single Prong Wall Hook**  
To be bolted to divisions and to back panel.

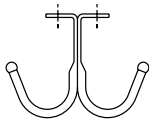

**Single & Double Prong Ceiling Hook**  
To be bolted to bottom of shelf or top of locker.

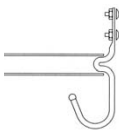

**Coat Rod Hooks with Rod**  
Hooks to be bolted to divisions with coat rod in between, used in single tier, Duplex, 2,7,8 person and Dual lockers 18" or more in depth.



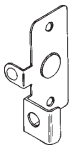

**Hook Clip**  
Used to attach single prong wall hooks and coat rod hooks in lockers with Diamond Perforated divisions at ends only.



**Door Pull**  
Used on box locker door unless a built-in lock is used. To be mounted on inside of door with pull tab inserted through vertical slot in door.

## Nuts and Bolts

10—24 x 3/8"  Truss fin head bolt and nut for assembly of Vanguard locker body parts. Tighten nut with a wrench or nut driver. (bolt is tamper resistant so it has no slot for a screw driver)

10—24 x 1/2"  Truss fin head bolt and nut for assembly of the entire Invincible II locker. In the Vanguard locker this nut and bolt is used in joining locker groups, locker legs and 2 hooks with the partition between the hooks. Tighten nut with a wrench or nut driver (bolt is tamper resistant so it has no slot for a screw driver)

NO. 8 x 3/8"  Sheet metal screw for slope tops only.

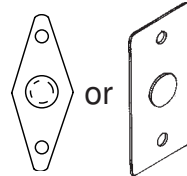

**Lock Hole Cover Plate**  
Used to cover hole in door when built-in locks are not used. To be mounted on inside of door.

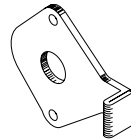

**Anti-Pry/Twist Bracket**  
Used on back of recessed pocket in Defiant Lockers (Single Point Latch).

## Optional Items That are Ordered Separately from Locker



**Combination Padlock** (9/32" or .281" Shackle)  
Used to secure locker door when built in lock is not used. Lock may come from another supplier other than Penco Products.



**Built-in Combination Lock**  
Used to secure locker door when padlock is not used. This lock replaces Lock Hole Cover Plate or Door Pull. To be mounted on inside of door. Lock may come from another supplier other than Penco Products.

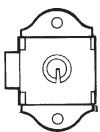

**Built-in Key Lock**  
Used to secure locker door when padlock is not used. This lock replaces Lock Hole Cover Plate or Door Pull. To be mounted on inside of door. Lock may come from another supplier other than Penco Products.



**Safe-O-Mat Coin Operated Lock**  
Used to secure locker door when padlock is not used. This lock replaces Lock Hole Cover Plate. Lock engages when token or coin is deposited.



**Locker Shoe**  
Can be used on the front legs of locker to secure to floor. Protects floor along with leveling lockers on an uneven floor.

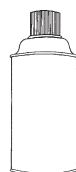

**Touch Up Paint**  
Used to touch up paint finish. Comes in 20 standard colors.

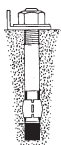

**Concrete Floor Anchor**  
1/4 x 2" Used to secure locker to a concrete floor. Bolt type will vary with floor type.

Single row lockers must be floor and wall anchored,  
double row lockers must be floor anchored and if possible wall or ceiling anchored.

# BASIC ASSEMBLY OF SINGLE ROW LOCKERS (A Grouping of 3 Single Tier Lockers Illustrated)

## Operation 1

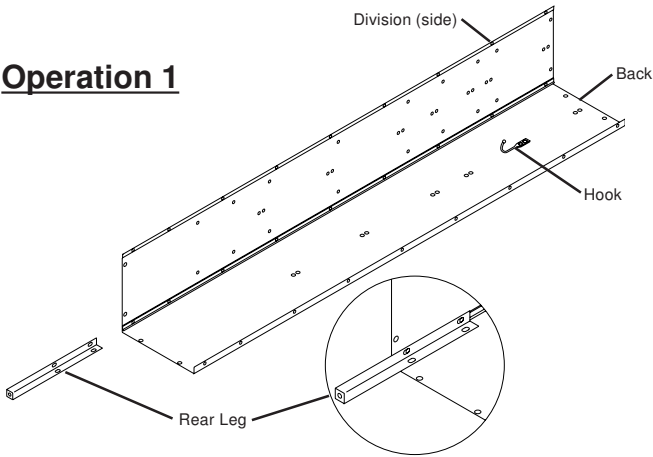

- A. Bolt hook to back. (Vanguard uses 10-24 x 3/8" truss fin bolts for body parts unless noted, Invincible II uses 10-24 x 1/2" truss fin head bolts for entire locker).
  - B. Bolt division and rear leg, if provided, to back (use 10-24 x 1/2 bolts for leg).
- NOTE: Hook type and placement varies with locker size and style. Refer to the table called **Hook and Coat Rod Guidelines** on page 6.*

## Operation 2

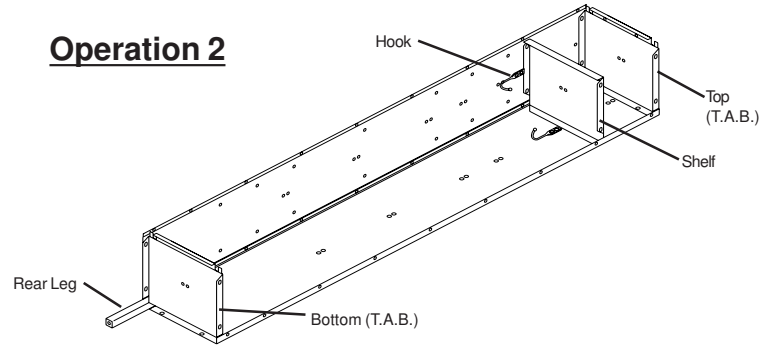

- A. Bolt top (T.A.B.), shelf, side hook and bottom (T.A.B.) to back and division (flat top and bottom are same part).
- NOTE: If assembling a Multi-Tier, Two Person, Duplex or Dual Locker, refer to the section on page 7, **Multi-Tier, Two Person, Duplex and Dual Lockers** to complete Operation 2. For Coat Rod Installation see page 4, **Installing Coat Rod**.*

## Operation 3

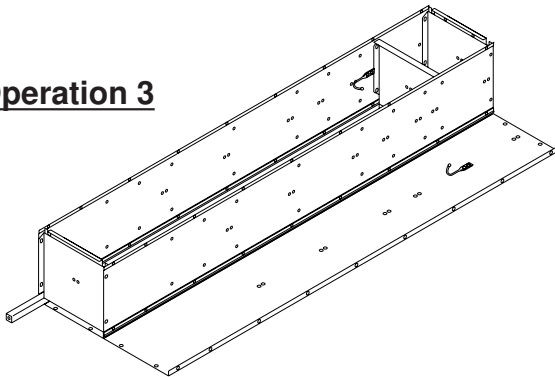

- A. Bolt hook to second back.
- B. Bolt second back and second division to first back.

## Operation 4

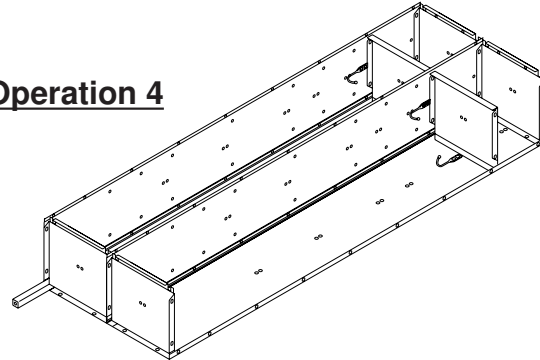

- A. Bolt second set of tops (T.A.B.), shelves, 2 hooks and bottoms (T.A.B.) to back and division. If coat rods are required install in first locker.
- B. Continue as in Operations 2 through 4 until desired number of units for the group are assembled, then proceed to Operation 5.

### Installing Coat Rod

(Add this step to Operation 2), before installing top (T.A.B.) and shelf, install coat rod hooks on the inside of divisions and (or) both sides of partition using the same bolt (where possible). Spread apart division and (or) partition and then insert coat rod into coat rod holder on coat rod hook.

### Guidelines for Rear Leg Spacing for Single Row Lockers

**IMPORTANT:** If lockers have been ordered with grouping specified, assemble lockers as ordered. Back legs should not exceed 45" distance between legs. If grouping has not been specified assemble lockers using the chart.

Width of Single Locker (inches)	7-1/2"	9"	12"	15"	18"	24"
Lockers in a Single Row Grouping	9	8	7	6	4	3
Back Legs in Each Grouping	9	6	5	4	3	2

*Single row lockers must be floor and wall anchored, double row lockers must be floor anchored and if possible wall or ceiling anchored.*

### Operation 5

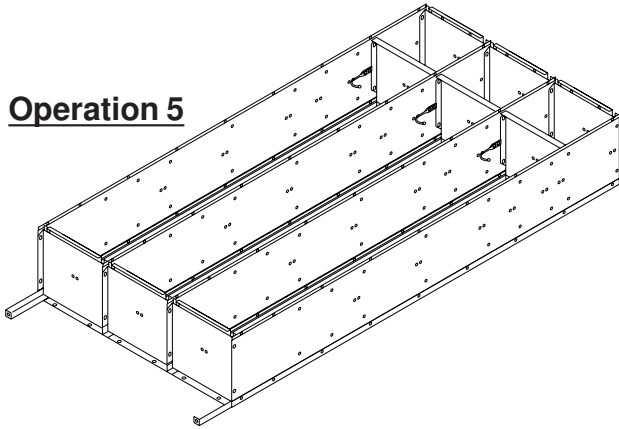

### Operation 6

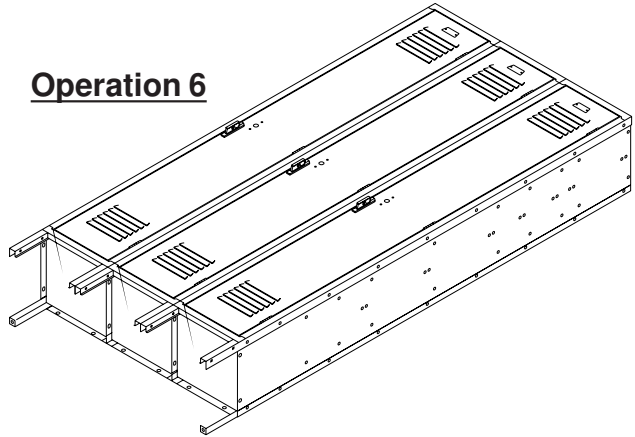

- A. Place second leg in position (between bottom and back). Distance between back legs not to exceed 45 inches.
- B. Place end division in position and bolt to top, shelf, hook, back leg and bottom (use 10- 24 x 1/2 bolts for leg). *NOTE: **Invincible II Lockers Only** see page 10 regarding group ends.*
- C. Bolt a double prong hook to each shelf (if supplied).
- A. Place door and frame assemblies in position with the top, bottom and end divisions inside the door frames and bolt to divisions, top and bottoms (T.A.B.). If two or more groups are to be joined in a row, omit bolts thru joining door frame and divisions. *NOTE: If closed bases are being used refer to **Closed Bases** on page 9. If grouping has not been specified, assemble lockers using the **Guidelines for Rear Leg Spacing** on page 4.*

Top View of Two Groupings of Three Lockers

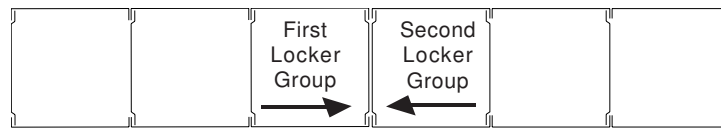

### Operation 7

- A. Set groups in place.
- B. Use 10-24 x 1/2 bolts to bolt joining door frames and backs of each locker group.
- C. Rivet number plates to top of doors.
- D. Bolt built-in locks or door pulls or lock hole cover plates to inside of door. *NOTE: If locker has a Defiant (Single Point Handle) use **Defiant Lockers: Assembly of Anti-Pry/Twist Bracket** instructions on page 6.*
- IMPORTANT:** When using locks do not close door unless you have keys or combination.

### Illustration of Number Plate, Lock Hole Cover Plate or Built-in Locks Positioning

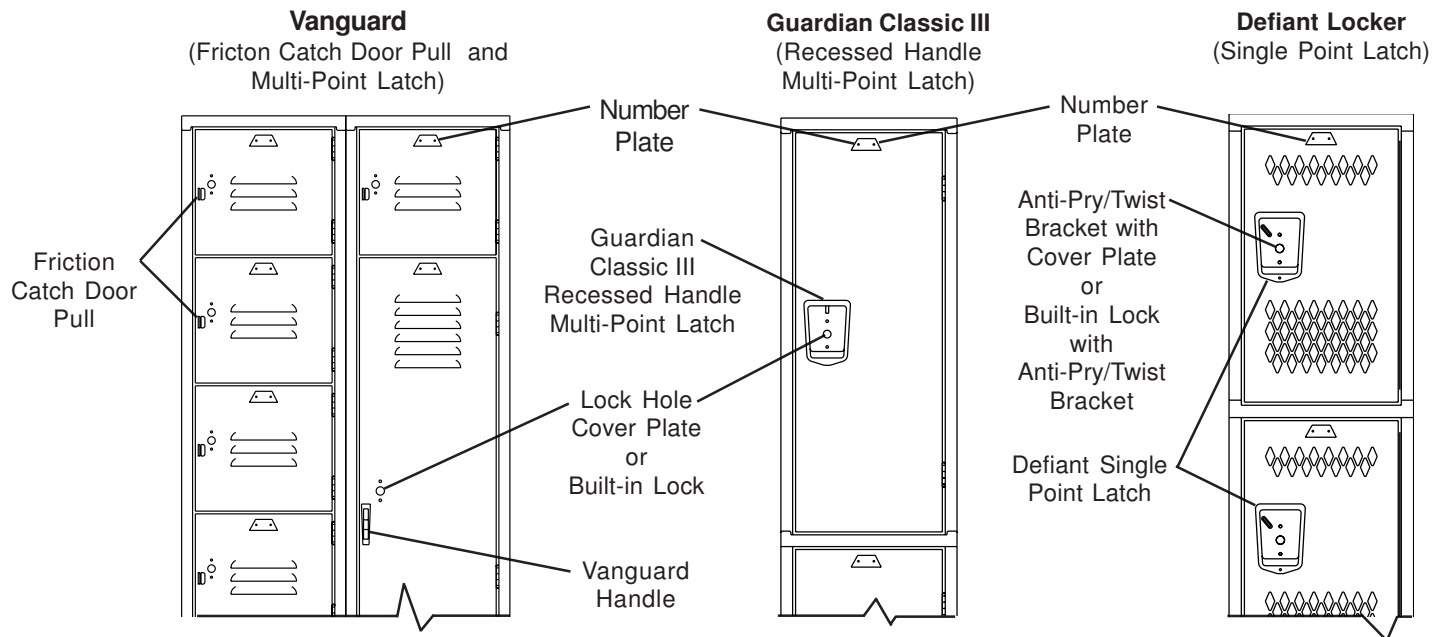

Single row lockers must be floor and wall anchored,  
double row lockers must be floor anchored and if possible wall or ceiling anchored.

## DEFIANT LOCKERS: Assembly of Anti-Pry/Twist Bracket

1. Locate the Anti-Pry/Twist Brackets, Locks (if ordered), Lock Hole Cover Plates and 3/8" long locker screws (if built-in combination locks are NOT used) and nuts.

2A. If combination locks are being installed, place the Anti-Pry/Twist Bracket on the back side of the recessed pocket first, followed by the back of the lock unit as shown in the drawing. Insert the combination dial mechanism in the front of the pocket, and attach with 2 nuts.

2B. If built-in locks are NOT being used, place the Anti-Pry/Twist Bracket on the back of the recessed pocket first, followed by a Lock Hole Cover Plate as shown in the drawing. Fasten with 3/8" locker screws and nuts.

*Note: Tighten nuts only finger tight at first. This will allow the bracket to stay in place during the next step of adjusting the bracket, but not restrict the bracket's movement in to proper alignment.*

3. Close the door. As the door is closed, the bracket will enter into the hasp and slide into its proper alignment. Open and close the door once or twice more to check alignment. A door with a properly aligned bracket will open and close smoothly with only a little resistance between bracket and friction catch.

4. Once the bracket is aligned, tighten the nuts using a 3/8" nut driver. Use care not to move the bracket out of alignment while tightening nuts. Open and close the door to check that alignment is unchanged.

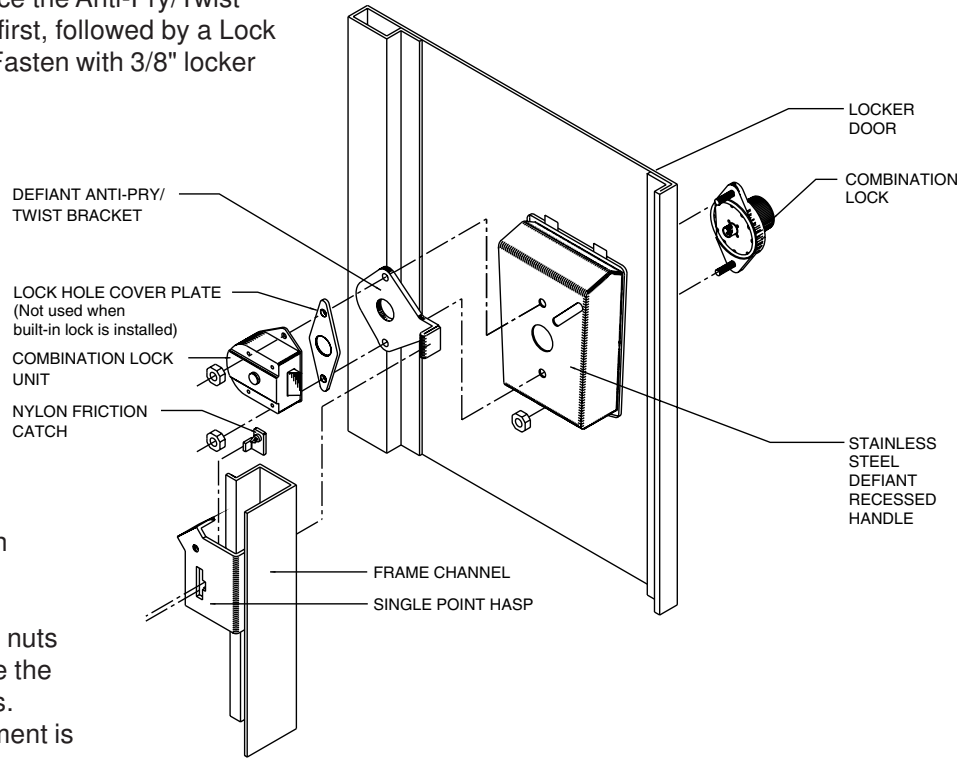

## Hook and Coat Rod Guidelines

Number of Pieces Supplied per Locker FRAME \*- Standard Construction Only

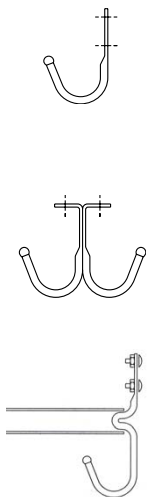

	1 Tier	2 Tier	3 Tier	4,5,6,8,9 Tier	2 Person	7 Person	8 Person	16 Person	Duplex	Dual
<b>Single Prong Hooks</b>										
Depth Less than 18" AND:										
... Width less than 15"	3	6	9	-	n/a	n/a	n/a	n/a	n/a	4
... Width =15" or more	4	8	12	-	4	n/a	n/a	n/a	4	4
Depth 18" or more AND:										
... Width less than 15"	1	6	12	-	n/a	-	-	n/a	n/a	-
... Width =15" or more	2	8	12	-	-	-	-	n/a	-	-
<b>Double Prong Hooks</b>										
Depth 18" or more	-	-	-	-	-	-	-	-	-	-
Depth LESS than 18" AND:										
... Width is LESS than 21"	1**	2	-	-	-	n/a	n/a	n/a	-	-
... Width is 21" or more	2	4	-	-	n/a	n/a	n/a	n/a	n/a	-
<b>Coat Rod Hooks</b>										
Depth Less than 18"	-	-	-	-	-	n/a	n/a	n/a	-	-
Depth 18" or more	2	-	-	-	4	2	4	-	4	4
<b>Coat Rods</b>										
Depth Less than 18"	-	-	-	-	-	n/a	n/a	n/a	-	-
Depth 18" or more	1	-	-	-	2	1	2	1	2	2

n/a: Not Applicable in Standard Construction

\*Exceptions: 7, 8 & 16 Person quantities are for entire unit.

\*\*Exception: Single Tier 9" wide x 15" deep has NO Double Prong Hooks

*Single row lockers must be floor and wall anchored,  
double row lockers must be floor anchored and if possible wall or ceiling anchored.*

# MULTI-TIER /TWO PERSON/DUPLEX AND DUAL ASSEMBLY INSTRUCTIONS

Assemble lockers using the Single or Double Tier Instructions, during **Operation 2** add the appropriate shelf, top, bottom or partition.

## Shelf Spacing Guidelines

**Single tier lockers** have a shelf approx. 9" below the top of the locker.

For **Multi-tier** locker take the height of the locker and divide the number of doors to get shelf spacing.

Example: *Height 72", Number of Doors 6, 72"/6 = 12" distance between shelves.*

Locker doors and frame can also be used as a template for shelf or flat top (T.A.B.) positioning.

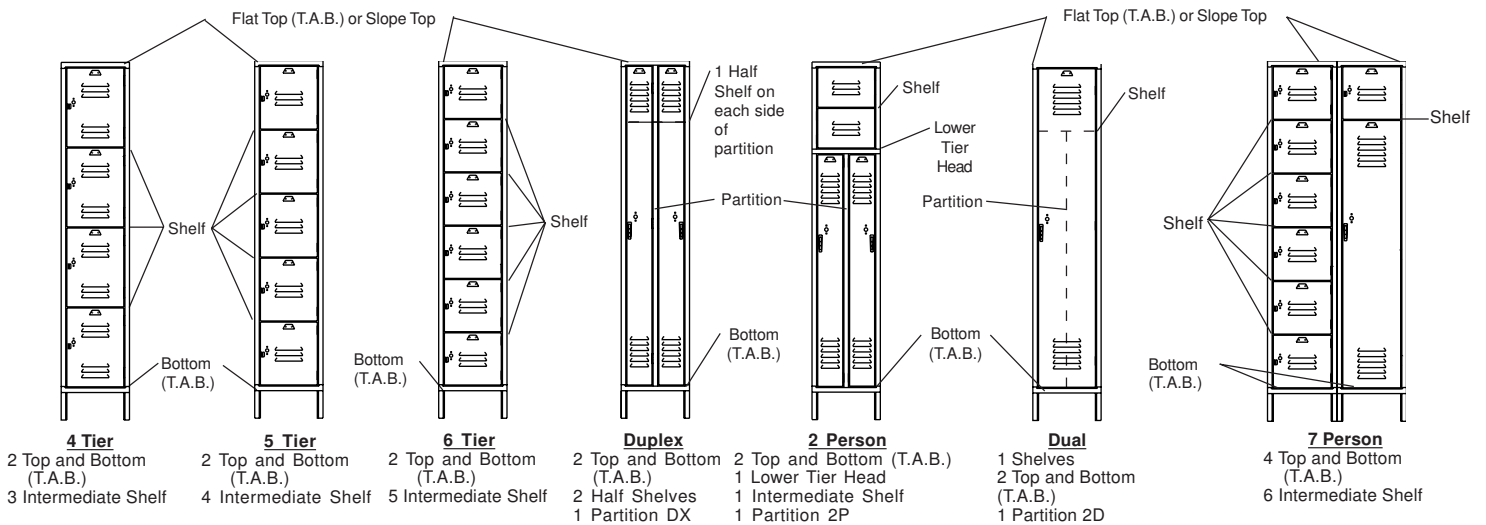
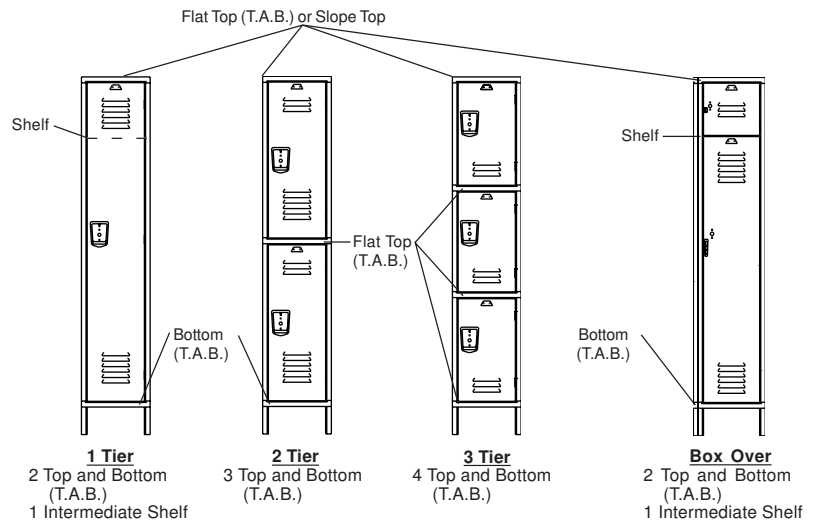

The hole punching pattern on Divisions are the same for all lockers except for 5 Tier Lockers and 16 gauge Exposed End Panels.

## 2 PERSON, DUPLEX AND DUAL LOCKER SUPPLEMENTAL INSTRUCTIONS

**2 Person** Bolt bottom (T.A.B.) to bottom of back and division. Bolt partition to bottom (T.A.B.). Bolt a Lower Tier Head to top of partition and divisions. Then bolt shelf above the top of partition. Bolt coat hooks on the inside of divisions and both sides of partition using the same bolt (where possible). Place top (T.A.B.) at top of locker and bolt to back and divisions. Proceed to Operation 3 of Assembly of Single Row or Double Row Lockers.

**Dual** Bolt bottom (T.A.B.) to bottom of back and division. Bolt partition to bottom. Install coat rod hooks on the inside of divisions and both sides of partition using the same bolt (where possible). Spread apart partition and division and insert coat rod into coat rod holder on coat rod hook. Place bottom of the shelf against top of partition and bolt to divisions. Place top (T.A.B.) at top of locker and bolt to back and divisions. Proceed to Operation 3 of Assembly of Single Row or Double Row Lockers.

**Duplex** Bolt bottom (T.A.B.) to bottom of back and division. Bolt partition to bottom (T.A.B.). Bolt 2 half shelves to each side of partition and divisions. Bolt coat hooks on the inside of divisions and both sides of partition using the same bolt (where possible). Place top (T.A.B.) at top of locker and bolt to back and divisions. Proceed to Operation 3 of Assembly of Single Row or Double Row Lockers.

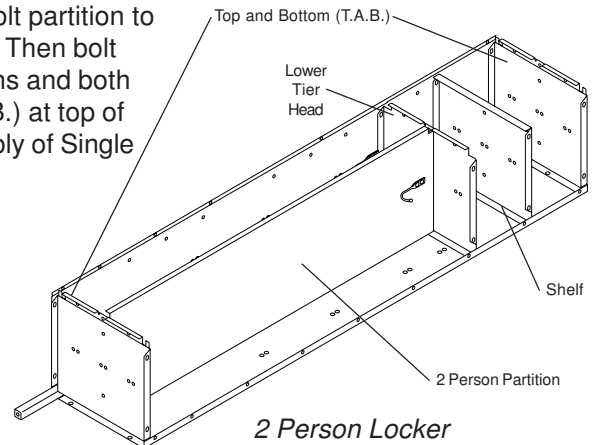

*Single row lockers must be floor and wall anchored,  
double row lockers must be floor anchored and if possible wall or ceiling anchored.*

# ASSEMBLY OF DOUBLE ROW (Back to Back) LOCKERS

(Single Tier Lockers used in Illustration)

## Operation 1

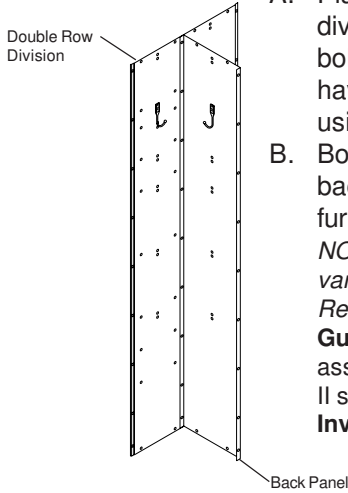

- A. Place a back and double row division in upright position and bolt together (double row lockers have back to back construction using a common back).
- B. Bolt coat hooks to division and back. (back legs are not furnished)

*NOTE: Hook type and placement varies with locker size and style. Refer to the table **Hook and Rod Guidelines** on page 6. If assembling Double Row Invincible II see page 9, **Double Row Invincible II Lockers Only**.*

## Operation 2

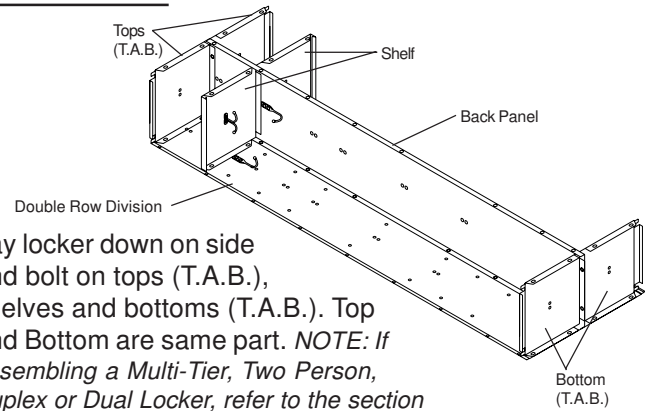

- A. Lay locker down on side and bolt on tops (T.A.B.), shelves and bottoms (T.A.B.). Top and Bottom are same part. *NOTE: If assembling a Multi-Tier, Two Person, Duplex or Dual Locker, refer to the section on page 7 labeled: **Multi-Tier, Two Person, Duplex and Dual Lockers** to complete Operation 2. For Coat Rod Instructions see page 4, **Installing Coat Rods**.*

## Operation 3

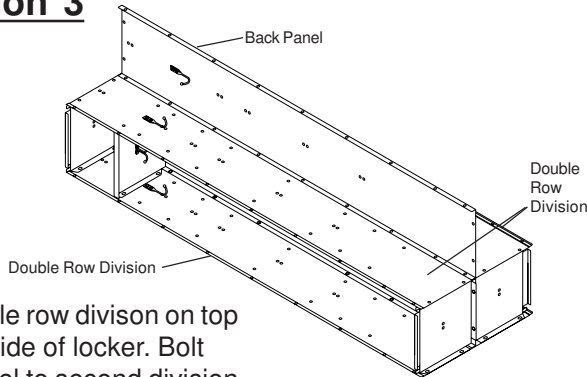

- A. Lay double row division on top of open side of locker. Bolt back panel to second division and the first back panel.
- B. Bolt coat hooks to both sides of second division and back.

## Operation 4

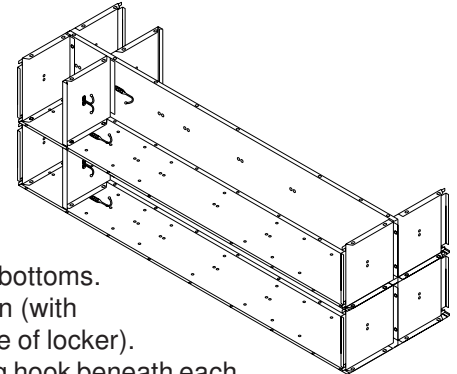

- A. Bolt on 2 sets of tops, shelves and bottoms.
- B. Bolt on end division (with offset toward inside of locker).
- C. Bolt a double prong hook beneath each shelf using 10—24 x 3/8".
- D. Continue as in Operations 3 and 4 until desired number of units for the group are assembled, then proceed to Operation 5.

## Operation 5

- A. Stand lockers upright and prop up the front of the locker. Then place door frame assemblies in position with the divisions inside the door frames. Bolt to divisions, tops and bottoms. If two or more groups are to be joined in a row, omit bolts thru joining door frames and divisions. *NOTES: If closed bases are being used refer to **Closed Bases** on page 9. **Invincible II Lockers Only** see page 10 regarding **Group End Kits**.*

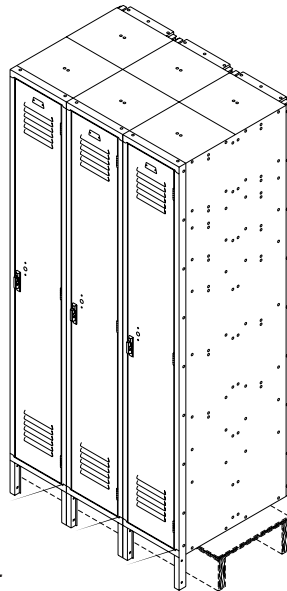

## Operation 6

- A. Set groups in place.
- B. Use 10-24 x 1/2 bolts to bolt joining door frames of each locker group.
- C. Rivet number plates to top of doors.
- D. Bolt built-in locks or lock hole cover plate to inside of door.

*For an **Illustration of Number Plate, Lock Hole Cover Plate or Built-in Locks Positioning**, see Operation 7 on page 5.*

**IMPORTANT** If lockers have been ordered with grouping specified, assemble lockers as ordered.

*Single row lockers must be floor and wall anchored, double row lockers must be floor anchored and if possible wall or ceiling anchored.*

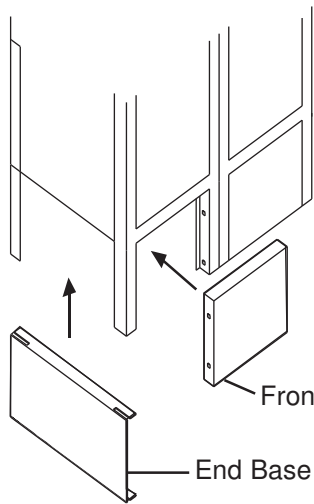

## INDIVIDUAL CLOSED BASES

Front and end bases are designed to fit between standard Penco 6" legs. The front base snaps in between the front legs. The end base slips over legs during locker assembly.

1. Before standing locker up and placing the locker in position, slide the End Base up the leg of the end of the locker row.
2. Stand locker up and put the lockers in proper position.
3. Snap Front Base between the front legs of each locker so that the two extruded tabs on either side of Front Base match up with the square slots in the front legs.

## ZEE BASE: for lockers to be anchored to wall

Zee Base raises lockers without legs off the floor and provides a continuous closed base. It is used when there is no concrete or wood base. Available in lengths of 72" only, the Zee Base shall be cut by installer when shorter lengths are needed.

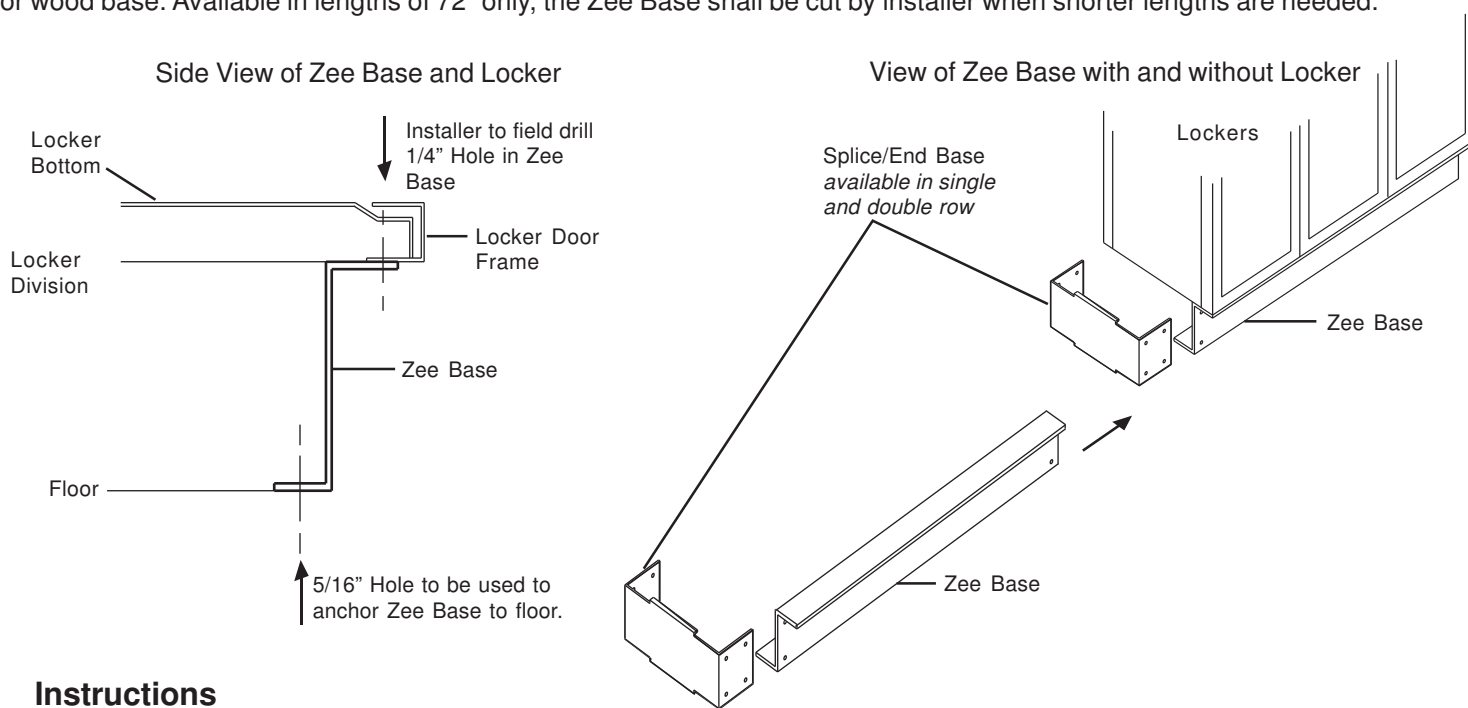

### Instructions

1. Match Zee Bases and Splice/End Bases to lockers, site plan and installation location.
2. Use Splice/End Base as a template to position Zee Base.
3. Place Splice/End Base flush against wall (thinner side with holes) or create a chalk line as a positioning guide.
4. Create a chalk line for Zee Base positioning using Splice/End Bases as a measuring device.
5. Butt Zee Base against other side of Splice/End Base.
6. Measure locker depth and make sure Locker Door Frame will rest on Zee Base. (there should be a 1/4 inch space between the end of Zee Base and outside edge of Locker Door Frame).
7. Use the two sets of holes on the Splice/End Base to bolt together 2 lengths of the Zee Base.
8. Recheck measurements of Locker, Zee Base position, and site plans.
9. Anchor Zee Bases and Splice/End Base to floor with proper drill and bolt for the floor surface.
10. Assemble Single Row Lockers as per instructions on page 4 or assemble Double Row Lockers as per instructions on page 8 except when installing Door and Door Frame leave bolts at bottom of Door Frame off.
11. Place assembled locker on Zee Base (there should be a 1/4 inches space between the end of Zee Base and outside edge of Locker Door Frame).
12. Use the bottom hole of the Door Frame to position drill and drill a 1/4" hole through the top of the Zee Base.
13. Place bolt through Door Frame and Zee Base. Place nut on Zee Base side of bolt and tighten. Repeat steps 12 and 13 for each door.

*Single row lockers must be floor and wall anchored,  
double row lockers must be floor anchored and if possible wall or ceiling anchored.*

## Unit Slope Tops

Unit Slope Tops are used with Slope Top Divisions. One Unit Slope Top covers the width of one locker frame. *(Not for use on Invincible II or All-Welded lockers.)*

1. Open door to locker so you have access to top of locker.
2. Bolt unit slope top to divisions and back.
3. Insert sheet metal screws up the hole in the top of the door frame and fasten the front of the unit slope top to locker.
4. Repeat steps 1-4 as needed.

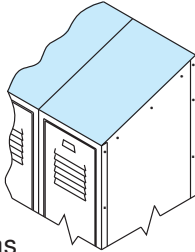

Unit Slope Tops			
Size (Inches)			Cat. No.
W	D	H	
9	12	-	60332C
9	15	-	60334C
9	18	-	60336C
12	12	-	60338C
12	15	-	60340C
12	18	-	60342C
12	21	-	60344C
15	12	-	603450C
15	15	-	60346C
15	18	-	60348C
15	21	-	60350C
18	18	-	60352C
18	21	-	60354C
18	24	-	60356C
24	18	-	60364C
24	21	-	60366C
24	24	-	60368C

## Slope Top Kit

Designed to convert stock flat top lockers into slope top lockers in groups of 3 wide. Each Kit contains 3 tops, 3 backs and 4 ends. *(Not for use on Invincible II or All-Welded lockers.)*

1. If there is a Flat Top (T.A.B.) on locker, remove bolts on sides and back.
2. Bolt Slope End to inside of locker.
3. Bolt Slope Back to outside of locker back and inside of Slope End.
4. Bolt slope top to sides and back.
5. Insert sheet metal screws up the hole in the top of the door frame and fasten the front of the slope top to locker.
6. Repeat steps 1-6 as needed.

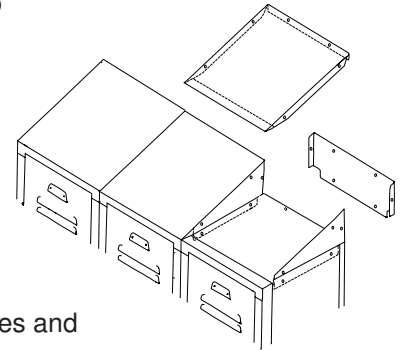

Slope Top Kits			
Size (Inches)			Cat. No.
W	D	H	
12	12	4	60230H
12	15	5	60232H
12	18	6	60234H
15	15	5	60238H
15	18	6	60240H
18	18	6	60244H

## Continuous Slope Hoods

Continuous slope hoods fit on top of flat top lockers. They can be used on new lockers, or on a retrofit basis. All hoods are furnished in 72" lengths and must be cut to length during installation. Intermediate splices, ends and rear supports (2 per hood) complete the installation, and must be ordered separately.

Slope Hoods			
Size (Inches)			Cat. No.
W	D	H	
72	12	5	66144H
72	15	6	66147H
72	18	7	66150H
72	21	8	66153H
72	24	9	66156H

Size (Inches)		Slope Ends		Hood Splice	Rear Support
D	H	LH	RH		
		Cat. No.		Cat. No.	Cat. No.
12	5	66158H	66159H	66168C	66173C
15	6	66160H	66161H	66169C	66174C
18	7	66162H	66163H	66170C	66175C
21	8	66164H	66165H	66171C	66176C
24	9	66166H	66167H	66172C	66177C

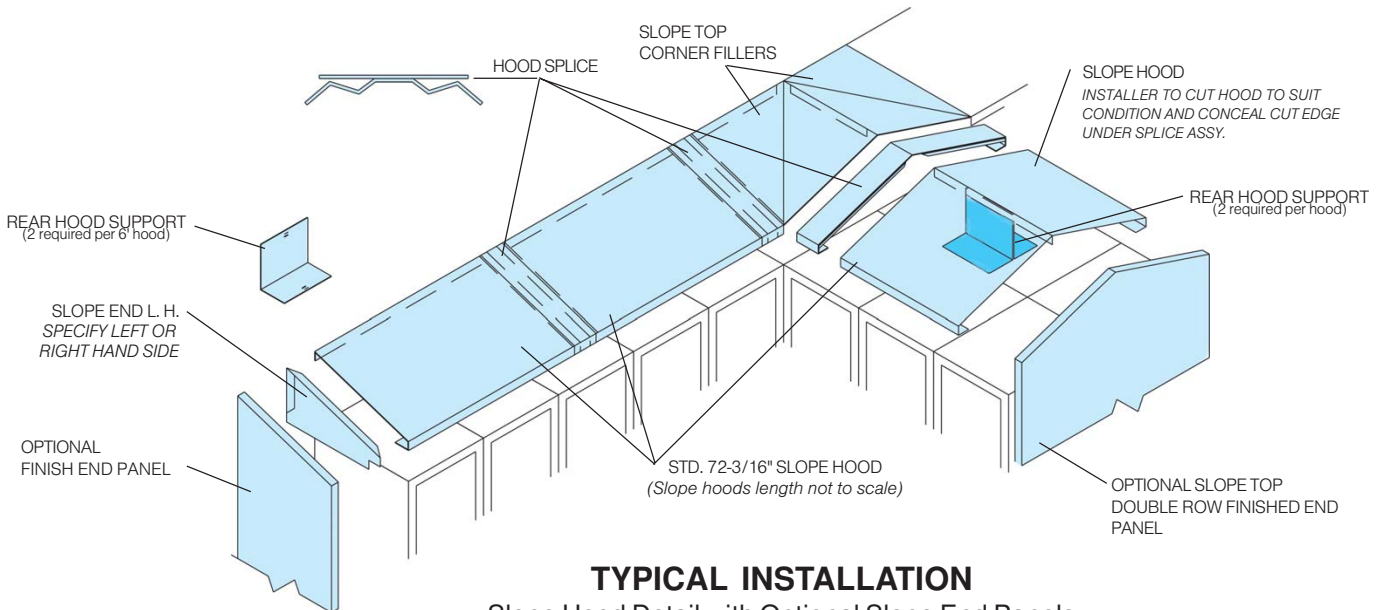

### TYPICAL INSTALLATION

Slope Hood Detail with Optional Slope End Panels

Single row lockers must be floor and wall anchored, double row lockers must be floor anchored and if possible wall or ceiling anchored.

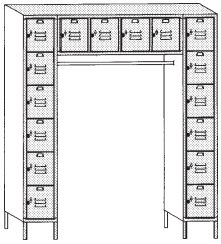

## 16 PERSON LOCKER ASSEMBLY INSTUCTIONS

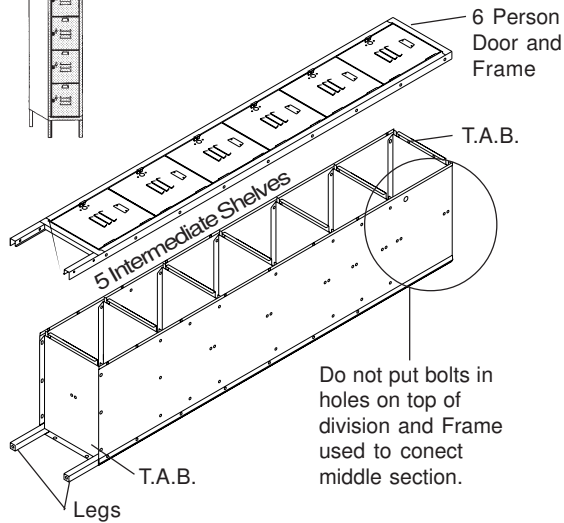

### END SECTIONS

#### Assembly of Right Hand 6 Tier Locker

1. Bolt division (10-24 x 3/8 truss fin bolts) to right side of back. Bolt rear legs (10-24 x 1/2 tuss fin bolts and washer) to each side of back.
2. Bolt T.A.B. to bottom of division, back and add left division to back.
3. Bolt 4 bottom intermediate shelves to each division and back.
4. Bolt top intermediate shelf and T.A.B. (top) to right division and back. Leave bolts off left division so middle section can be joined.
5. Install door and frame assembly over divisions, top and bottom (T.A.B.) and bolt into place. Leave top two bolt holes empty on left side so middle section can be installed.

#### Assembly of Left Hand 6 Tier Locker

1. Assemble left side (6 tier locker) according to the above instructions but leave bolts off top of right division so middle section can be joined.
2. Install door and frame assembly over panels, top and T.A.B. and bolt into place. Leave top two bolt holes empty on left side so middle section can be installed.

### MIDDLE SECTION

1. Separate flat 16 person top from bottom. The 16 person bottom has a larger front offset and no holes in offset.
2. Bolt three 16 person dividers to 16 person bottom.
3. Bolt 16 person top to 16 person dividers and back.
4. Place 16 person door and frame assembly over 16 person top and bottom's offset and bolt into place.

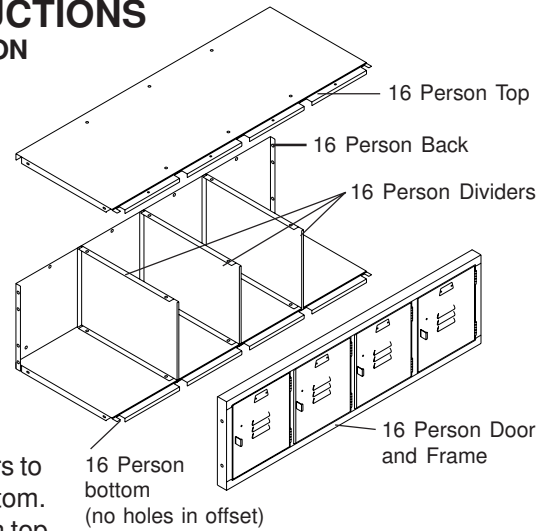

### FINAL ASSEMBLY

1. Rest locker section on flat surface and bolt center section to left and right 6 person lockers.
2. Stand locker upright.
3. Bolt coat rod bracket to one side of 6 person locker (End Section) below center section.
4. Insert coat rod into coat rod bracket. Place remaining rod bracket in open end of rod and maneuver rod and coat rod bracket to mounting hole on other 6 person locker and bolt into place.
5. Rivet number plate to doors.
6. Incert door pulls through slot in each door and bolt door pull to door.
7. Anchor locker to floor and wall.

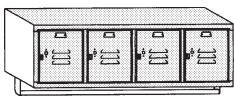
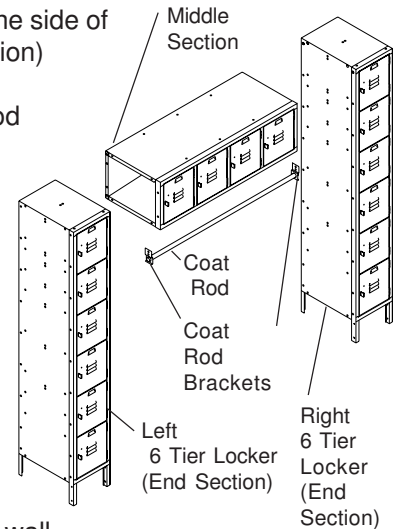

## WALL MOUNTED LOCKER WITH COAT ROD

1. Use steps 1-3 from the Middle Section of the 16 Person Lockers Instructions above.
2. Bolt a 4 compartment locker end to each side of middle section.
3. Bolt the coat rod retaining plate to each side of 4 compartment locker end (end section). Bolt a 4 compartment coat hanging plate to one coat rod bracket.
4. Carefully inserts push-in thread washer 3/4" deep into each end of coat rod.
5. Insert coat rod into the attached coat rod bracket. Place remaining coat hanging plate in open end of coat rod and maneuver coat rod and coat rod hanging plate to mounting holes in the coat rod retaining plate and bolt into place.
6. Put 1/4-20 x 1-1/4" tuss head fin bolt into hole in coat rod retaining plate and coat hanging plate. Thread bolt in to push-in thread washer (in coat rod) and tighten bolts.
7. Insert door pulls through slot in each door and bolt door pull to door. Attach number plates to doors.
8. Anchor wall mounted locker to wall in 4 palces with appropriate anchor bolt for wall. Place anchor bolt through hanging plate and then locker back (holes may need to be drilled) and bolt to wall.

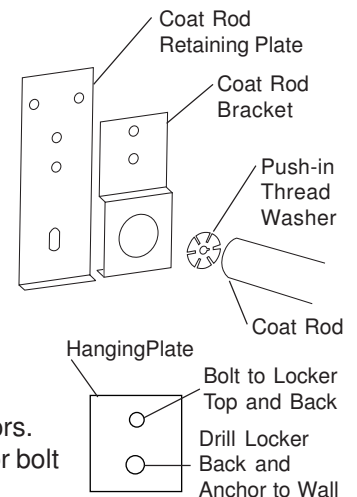

# INVINCIBLE II LOCKERS

## Invincible II Group End Kits

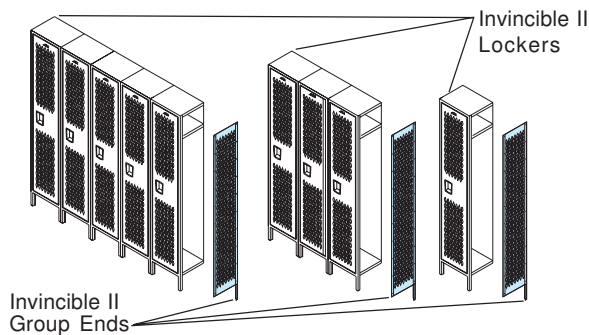

Invincible II lockers do not automatically come with group ends, they must be ordered separately. If you are short group ends, check with the person who ordered the lockers.

*NOTE: solid divisions (group ends) are sometimes ordered to end rows of lockers that have perforated divisions everywhere else. Refer to drawings provided by the person who ordered the lockers for all layout details.*

## Double Row Invincible II Lockers

Invincible II lockers do not use a double row division. Two single row divisions are joined together with a back angle and use a common back. This back angle is bolted to the back and then bolted to the division of the second row of lockers. Add these steps to **Operation 1 and 3** of the **Assembly of Double Row (Back to Back) Lockers** on page 8.

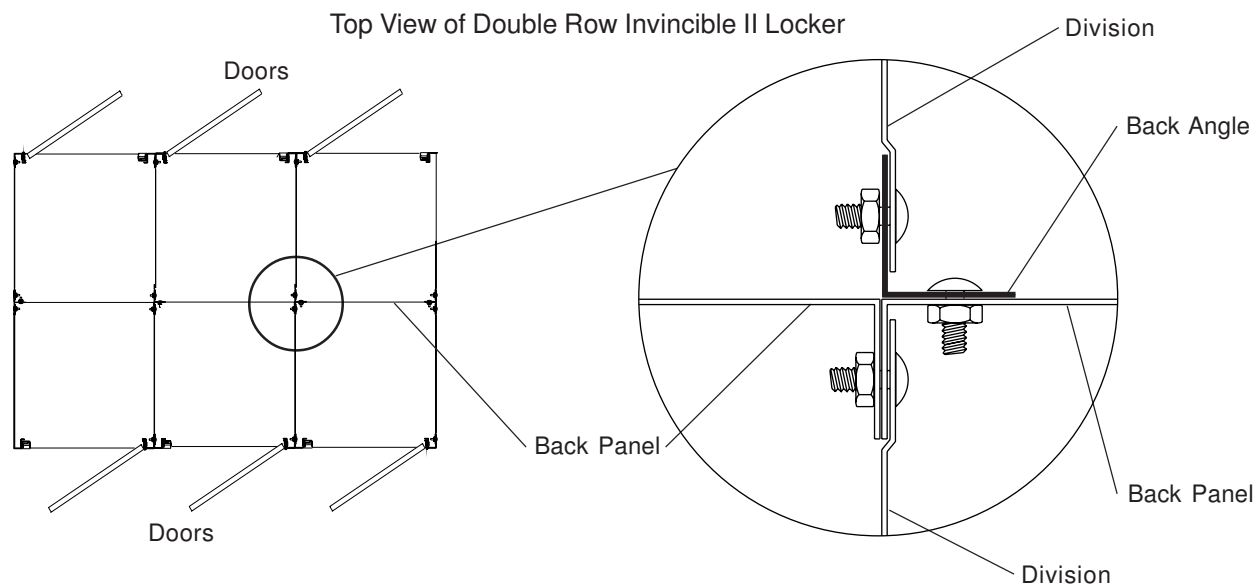

**PENCO PRODUCTS, INC.**  
99 Brower Ave., PO Box 378,  
Oaks, PA 19456-0378  
800-562-1000 • Fax 610-666-7561  
***www.pencoproducts.com***